

mitsubishi

D/A Converter Module

User's Manual
(Hardware)

A1S62DA

Thank you for buying the Mitsubishi general-purpose programmable controller MELSEC-A Series

Prior to use, please read both this manual and detailed manual thoroughly and familiarize yourself with the product.



MODEL	A1S62DA(H/W)-U-E
MODEL CODE	13JE43
IB (NA)-66482-E(1112) MEE	

● SAFETY PRECAUTIONS ●

(Read these precautions before using this product.)

Before using this product, please read this manual and the relevant manuals carefully and pay full attention to safety to handle the product correctly.

These precautions apply only to the installation of Mitsubishi equipment and the wiring with the external device. Refer to the user's manual of the CPU module to be used for a description of the PLC system safety precautions.

In this manual, the safety precautions are classified into two levels:

" WARNING" and " CAUTION".

WARNING

Indicates that incorrect handling may cause hazardous conditions, resulting in death or severe injury.

CAUTION

Indicates that incorrect handling may cause hazardous conditions, resulting in minor or moderate injury or property damage.

Under some circumstances, failure to observe the precautions given under " CAUTION" may lead to serious consequences.

Observe the precautions of both levels because they are important for personal and system safety.

Make sure that the end users read this manual and then keep the manual in a safe place for future reference.

[DESIGN PRECAUTIONS]

WARNING

- Install a safety circuit external to the PLC that keeps the entire system safe even when there are problems with the external power supply or the PLC module. Otherwise, trouble could result from erroneous output or erroneous operation.
 - (1) The analog output state will differ according to the setting state of the various functions for controlling the analog output.
For details, refer to manual Section 3.4.4 on the analog output state.
 - (2) If there is a fault in the output element or the internal circuit, correct outputs may not be possible or erroneous outputs may be made.
Provide a circuit to externally monitor output signals that could lead to major faults.

CAUTION

- Do not bunch the control wires or communication cables with the main circuit or power wires, or install them close to each other.
They should be installed 100mm (3.94inch) or more from each other.
Not doing so could result in noise that would cause erroneous operation.
- At power ON/OFF, voltage or current may instantaneously be output from the output terminal of this module. In such case, wait until the analog output becomes stable to start controlling the external device.

[INSTALLATION PRECAUTIONS]

CAUTION

- Use the programmable controller in an environment that meets the general specifications in the user's manual for the CPU module used.
Using this PLC in an environment outside the range of the general specifications could result in electric shock, fire, erroneous operation, and damage to or deterioration on the product.
- Securely insert the module fixing latch on the module bottom into the fixing holes on the base unit before mounting. Incorrect mounting of the module could lead to erroneous operation, faults or drop.

[WIRING PRECAUTIONS]

CAUTION

- When wiring in the PLC, be sure that it is done correctly by checking the product's rated voltage and the terminal layout.
Connecting a power supply that is different from the rating or incorrectly wiring the product could result in fire or damage.
- Tighten the terminal screws with the specified torque.
If the terminal screws are loose, it could result in short circuits, fire, or erroneous operation.
- Be sure there no foreign substances such as sawdust or wiring debris inside the module.
Such debris could cause fires, damage, or erroneous operation.

[STARTUP AND MAINTNANCE PRECAUTIONS]

WARNING

- Externally shut off all power phases before touching the terminals.
Failure to observe this could lead to erroneous operation.
- Be sure to shut off all phases of the external power supply used by the system before cleaning or retightening the terminal screws.
Not doing so can cause the module to fail or malfunction.

CAUTION

- Do not disassemble or modify the module.
Doing so could cause trouble, erroneous operation, injury, or fire.
- Be sure to shut off all phases of the external power supply used by the system before mounting or removing the module. Not doing so may cause damage to the module.
- Do not install/remove the terminal block more than 50 times after the first use of the product. (IEC 61131-2 compliant)
- Before handling the module, always touch grounded metal, etc. to discharge static electricity from the human body.
Failure to do so may cause the module to fail or malfunction.

[DISPOSAL PRECAUTIONS]

CAUTION



- When disposing of the product, handle it as industrial waste.

●安全注意事项●

(使用之前请务必阅读)

在使用本产品之前，应仔细阅读本手册以及本手册中所介绍的相关手册，同时在充分注意安全的前提下正确操作。

本手册中的注意事项仅记载与本产品有关的内容。关于可编程控制器系统方面的安全注意事项，请参阅所使用的CPU模块的用户手册。

在“安全注意事项”中，安全注意事项被分为“警告”和“注意”两个等级。



表示错误操作可能造成危险后果，导致死亡或重伤事故。



表示错误操作可能造成危险后果，导致中度伤害、轻伤或财产损失。

此外，根据情况不同，即使标注为“注意”的事项也有可能引发严重后果。

这两个等级的注意事项记载的均为重要内容，请务必遵守。

请妥善保管本手册以备需要时取阅，并将本手册交给最终用户。

【设计注意事项】

警告

- 应在可编程控制器外部设置一个安全电路，以保证整个系统在外电源异常或可编程控制器本体故障时也能安全运行。
否则可能由于误输出、误动作而导致事故发生。
 - (1) 模拟输出的状态会因控制模拟输出的各种功能的设置状态而异。设置时应充分注意。
关于模拟输出状态的详细内容，请参照详细手册的 3.4.4 项。
 - (2) 由于输出元件或其内部电路的故障，有时可能会无法正常输出或会异常输出。对于可能导致重大事故发生的输出信号，应在外部设置监视电路。

注意

- 请勿将控制线及通信电缆与主电路及动力线等捆扎在一起或相互靠得太近。应相距大约 100mm 以上距离。因为噪声有可能导致误动作。
- 电源接通 / 关闭时瞬间可能会有电压或电流从输出端子输出。请在模拟输出稳定后再开始控制。

【安装注意事项】

注意

- 应在所使用的 CPU 模块用户手册记载的一般规格环境下使用可编程控制器。
如果在一般规格范围以外的环境中使用可编程控制器，可能导致触电、火灾、误动作、产品损坏或性能劣化。
- 请将模块下部的固定用凸起部切实插入基板的固定孔后，以规定的扭矩拧紧模块安装螺栓。
如果模块未正确安装并以螺栓固定，有可能造成误动作、故障或掉落。

【配线注意事项】

注意

- 进行可编程控制器配线作业时，应在确认产品的额定电压及端子排列的基础上正确进行操作。
如果连接了与额定值不符的电源或配线错误，可能导致火灾或故障。
- 应在规定的扭矩范围内拧紧端子螺栓。
如果端子螺栓拧得过松，有可能导致短路或误动作。如果端子螺栓拧得过紧，有可能造成螺栓及模块破损从而导致掉落、短路或误动作。
- 应注意防止切屑及配线头等异物掉入模块内。
否则有可能导致火灾、故障或误动作。

【启动 / 维护注意事项】

警告

- 在通电状态下请勿触摸端子。否则可能导致误动作。
- 在清洁模块或重新紧固端子螺栓时，必须将系统使用的外部供应电源全部断开后再进行操作。如果未全部断开，有可能导致模块故障或误动作。

注意

- 请勿拆解或改造各模块。否则可能导致故障、误动作、人身伤害或火灾。
在拆装模块时，必须将系统使用的外部供应电源全部断开后再进行操作。如果未全部断开，有可能导致模块故障或误动作。
- 产品投入使用后，端子排的拆装次数不应超过 50 次。（根据 IEC61131-2 规范）
- 在触碰模块之前，必须先触碰已接地的金属等，释放掉人体等所携带的静电。如果不释放掉静电，有可能导致模块故障或误动作。

【报废处理注意事项】

注意

- 本产品报废时，应当作工业废物处理。

● CONDITIONS OF USE FOR THE PRODUCT ●

- (1) Mitsubishi programmable controller ("the PRODUCT") shall be used in conditions;
- i) where any problem, fault or failure occurring in the PRODUCT, if any, shall not lead to any major or serious accident; and
 - ii) where the backup and fail-safe function are systematically or automatically provided outside of the PRODUCT for the case of any problem, fault or failure occurring in the PRODUCT.
- (2) The PRODUCT has been designed and manufactured for the purpose of being used in general industries.

MITSUBISHI SHALL HAVE NO RESPONSIBILITY OR LIABILITY (INCLUDING, BUT NOT LIMITED TO ANY AND ALL RESPONSIBILITY OR LIABILITY BASED ON CONTRACT, WARRANTY, TORT, PRODUCT LIABILITY) FOR ANY INJURY OR DEATH TO PERSONS OR LOSS OR DAMAGE TO PROPERTY CAUSED BY the PRODUCT THAT ARE OPERATED OR USED IN APPLICATION NOT INTENDED OR EXCLUDED BY INSTRUCTIONS, PRECAUTIONS, OR WARNING CONTAINED IN MITSUBISHI'S USER, INSTRUCTION AND/OR SAFETY MANUALS, TECHNICAL BULLETINS AND GUIDELINES FOR the PRODUCT.

("Prohibited Application")

Prohibited Applications include, but not limited to, the use of the PRODUCT in;

- Nuclear Power Plants and any other power plants operated by Power companies, and/or any other cases in which the public could be affected if any problem or fault occurs in the PRODUCT.
- Railway companies or Public service purposes, and/or any other cases in which establishment of a special quality assurance system is required by the Purchaser or End User.
- Aircraft or Aerospace, Medical applications, Train equipment, transport equipment such as Elevator and Escalator, Incineration and Fuel devices, Vehicles, Manned transportation, Equipment for Recreation and Amusement, and Safety devices, handling of Nuclear or Hazardous Materials or Chemicals, Mining and Drilling, and/or other applications where there is a significant risk of injury to the public or property.

Notwithstanding the above, restrictions Mitsubishi may in its sole discretion, authorize use of the PRODUCT in one or more of the Prohibited Applications, provided that the usage of the PRODUCT is limited only for the specific applications agreed to by Mitsubishi and provided further that no special quality assurance or fail-safe, redundant or other safety features which exceed the general specifications of the PRODUCTS are required. For details, please contact the Mitsubishi representative in your region.

About the Manuals

The following product are available for this equipment.
Refer to the table given below to choose suitable manuals.

Detailed Manual

Manual name	Manual No. (Model code)
D/A converter module type A1S62DA User's Manual	IB-66335

COMPLIANCE WITH EMC AND LOW VOLTAGE DIRECTIVES

(1) Method of ensuring compliance

To ensure that Mitsubishi programmable controllers maintain EMC and Low Voltage Directives when incorporated into other machinery or equipment, certain measures may be necessary. Please refer to one of the following manuals.

- User's manual for the CPU module used
- User's manual (hardware) for the CPU module or base unit used

The CE mark on the side of the programmable controller indicates compliance with EMC and Low Voltage Directives.

(2) Additional measures

No additional measures are necessary for the compliance of this product with EMC and Low Voltage Directives.

1. General Description

This manual describes specifications, handling and wiring of an A1S62DA D/A converter module (hereinafter referred to as the A1S62DA).

2. Specifications

Item		Specifications							
		Voltage Output				Current Output			
Digital input	1/4000	-4000 to 4000				0 to 4000			
	1/8000	-8000 to 8000				0 to 8000			
	1/12000	-12000 to 12000				0 to 12000			
Analog output		-10 to 0 to 10 VDC (External load resistance: 2KΩ to 1MΩ)				0 to 20mADC (External load resistance: 0 to 600Ω)			
I/O characteristics	Resolution	1/4000 1/8000 1/12000	1/8000		Analog output value *1	1/4000 1/8000 1/12000	1/8000		Analog output value *2
	Digital input value	4000	8000	12000	10V	4000	8000	12000	20mA
		2000	4000	6000	5V	2000	4000	6000	12mA
		0	0	0	0V	0	0	0	4mA
		-2000	-4000	-6000	-5V				
		-4000	-8000	-12000	-10V				
Maximum resolution of analog value	1/4000	2.5mV		(10V)	5μA		(20mA)		
	1/8000	1.25mV		(10V)	2.5μA		(20mA)		
	1/12000	0.83mV		(10V)	1.7μA		(20mA)		
Overall accuracy (accuracy to the maximum value)		±1% (±100mV)				±1% (±200μA)			
Maximum conversion time		Maximum 25ms/2 channels (same for 1 channel)							
Absolute maximum output		Voltage:±12V Current:+28mA							
Output short circuit protection		Provide							
Analog output points		2 channels/module							
Isolation method		Photocoupler insulation between output terminals and PLC power No insulation between channels							
Number of I/O points		32 points							
Connection terminal		20-points terminal block							
Offset/gain adjustment		By the test terminal (without using offset/gain adjusting knobs)							
Applicable wire size		0.75 to 1.5mm ²							
Applicable crimp terminal		1.25-3, 1.25-YS3A, V1.25-3, V1.25-YOS3A							
Internal current consumption (5VDC)		0.8A							
Weight (kg)		0.32kg							

The gain is set to 10V and the offset to 0V as the default.



*1 When the offset value is set to 0V and the gain value is set to 10V.

*2 When the offset value is set to 4mA and the gain value is set to 20mA.

Refer to the user's manual of the programmable controller CPU for the general specifications.

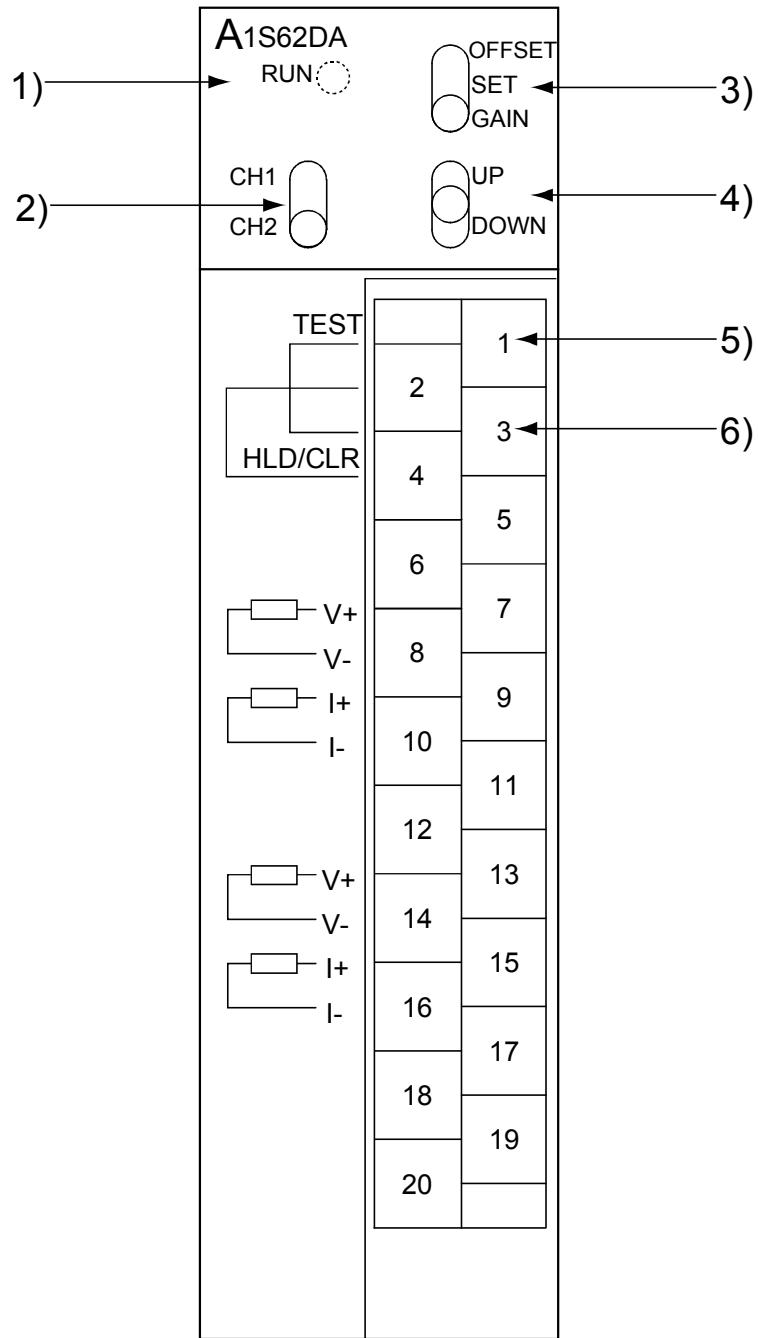
3. Nomenclature

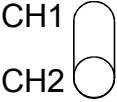

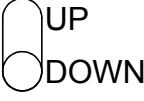
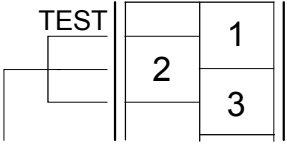
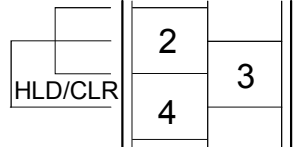
No	Description	Application
1)	<p>“RUN” LED</p> 	<p>Indicates the operating status of the A1S62DA. (Normal mode) On :Indicates that the A1S62DA is functional. Off :The 5 VDC power is not supplied or A1S62DA is faulty. Flash :When a digital value is written which is outside the high or low limit, this LED flashes every second. (Test mode) Off :OFFSET/GAIN select switch is in the “SET” position. Flash :When the offset/gain select switch is set to either the OFFSET or GAIN position, this LED flashes every half (0.5) second. When the offset or gain has reached the upper or lower limit, this LED flashes every tenth (0.10) of a second.</p>
2)	<p>Channel select switch</p> 	<p>Used to specify a channel for the offset/gain adjustment.</p>
3)	<p>OFFSET/GAIN select switch</p> 	<p>OFFSET position: Sets the offset value. GAIN position: Sets the gain value. SET position: The offset/gain value is stored to the A1S62DA internal memory when the switch is moved from “OFFSET”/”GAIN” to “SET”.</p>
4)	<p>UP/DOWN switch</p> 	<p>Increases or decreases the offset/gain value of the specified channel.</p>
5)	<p>Test mode terminals</p> 	<p>Connected between terminals No.1 and No.3 to set the offset/gain values</p>
6)	<p>Output HOLD/CLEAR setting terminals</p> 	<p>Used to hold or clear the analog output at the time of CPU STOP. Disconnected between terminal No.2 and No.4: CLEAR Connected between terminal No.2 and No.4: HOLD</p> <p>The analog output status of the HOLD/CLEAR setting varies with the setting of the D-A conversion value output enable flag and the analog output enable/disable state.</p>

3.1 Setting offset and gain

If the I/O conversion characteristics are to be changed, use the procedure shown below.

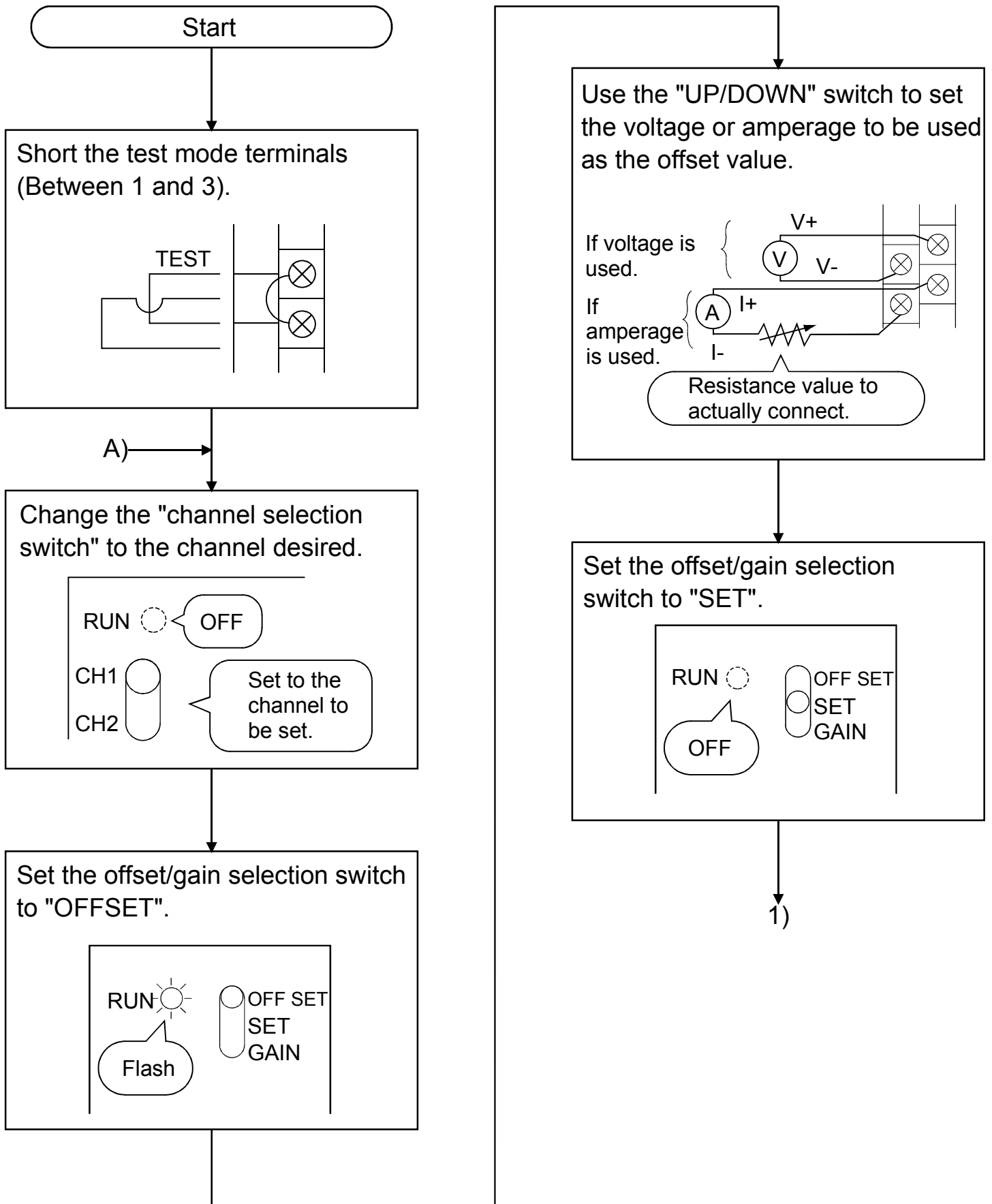

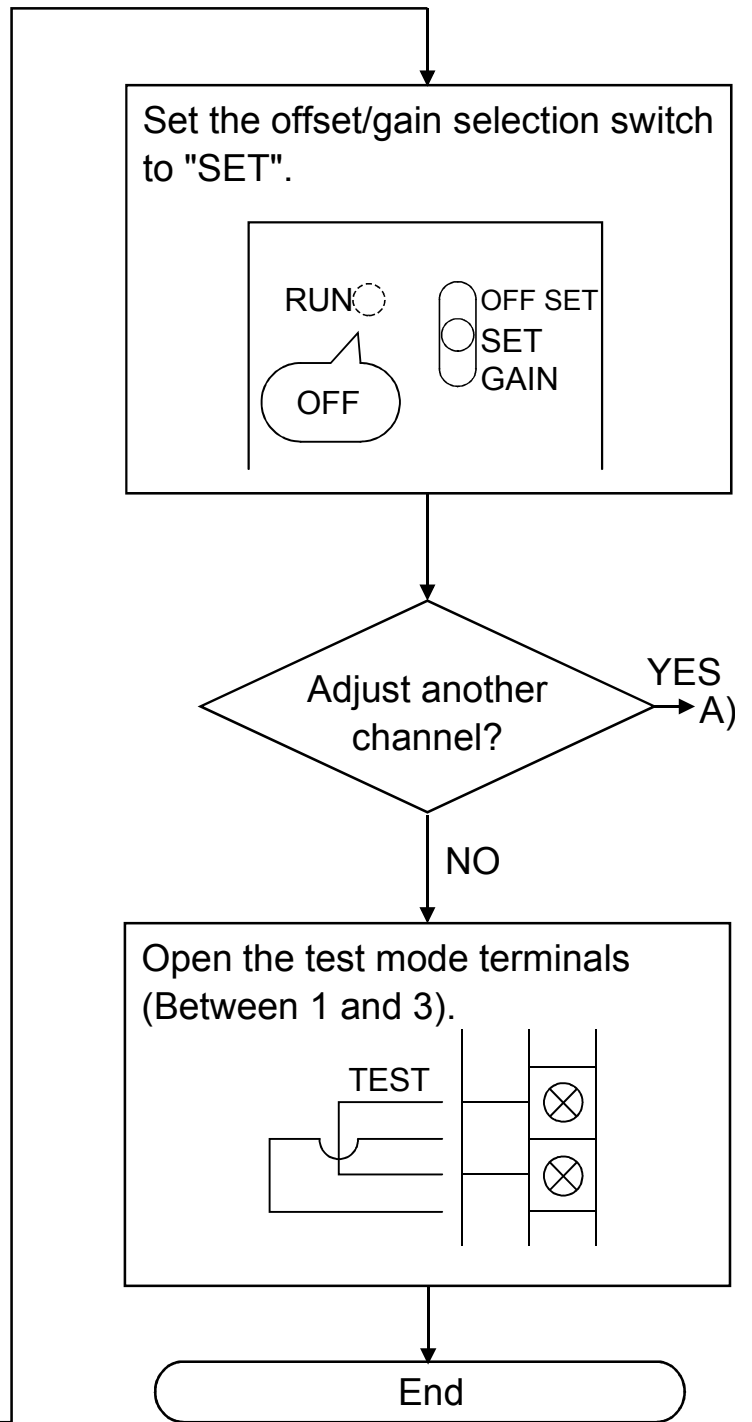
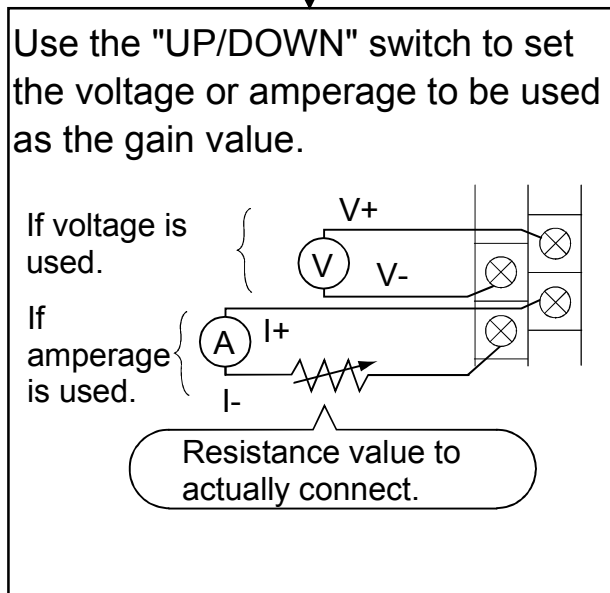
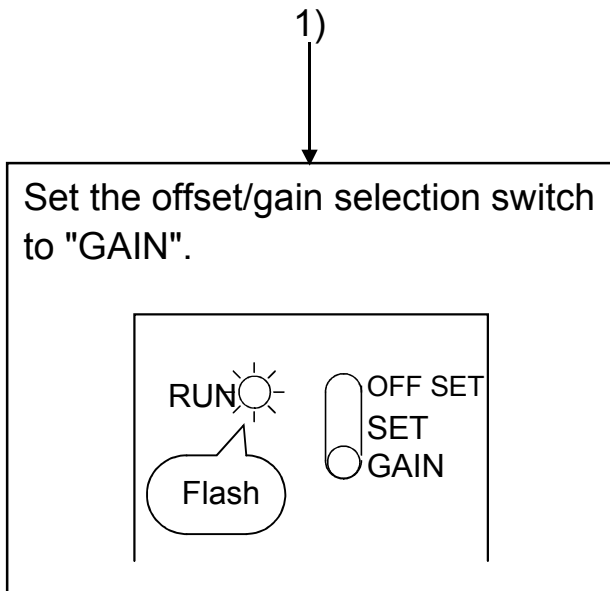

Reference

The offset value and gain value are as shown below.

- 1) Offset value This is the current or voltage output from the A1S62DA when the digital value that has been set from the PLC CPU is "0".
- 2) Gain value This is the current or voltage output from the A1S62DA when the digital value that has been set from the PLC CPU is "4000" (when digital resolution value is 1/4000).

4. Handling

4.1 Precautions for handling

- (1) The main body case and terminal block are made of resin, so do not drop them or apply strong impacts.
- (2) Do not remove the module PCB from the case. Doing so could lead to faults.
- (3) Make sure that foreign matter, such as wire scraps, does not enter from the top of the module during wiring. Remove any foreign matter that does enter.
- (4) Tighten the module installation screws and terminal screws within the following ranges.

Screw position	Tightening torque range
Module installation screw (M4 screw)	78 to 118N • cm
Terminal block terminal screw (M3.5 screw)	59 to 88N • cm
Terminal block installation screw (M4 screw)	78 to 118N • cm

5. Wiring

5.1 Wiring instructions

- (1) Separate the main power circuit and/or high voltage wiring from the control and signal wiring.
- (2) Where applicable, ground the shielding of all wires to a common ground point.

5.2 Connection of A1S62DA and external devices

- (1) Shows wiring example with the external device when there is voltage output.

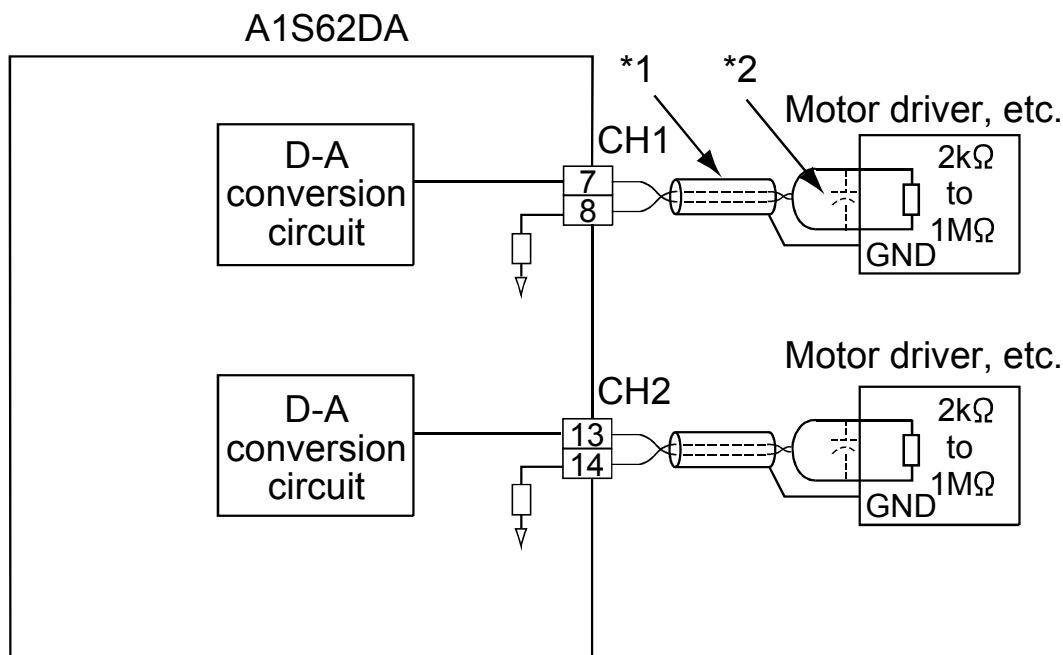

*1: Use two-core shielded wiring (twisted).

*2: If noise or ripple is generated by the external wiring, connect a 0.1 to 0.47μF (25V or more voltage resistance parts) to the input terminal of the external device.

(2) Shows wiring example with the external device when there is current output.

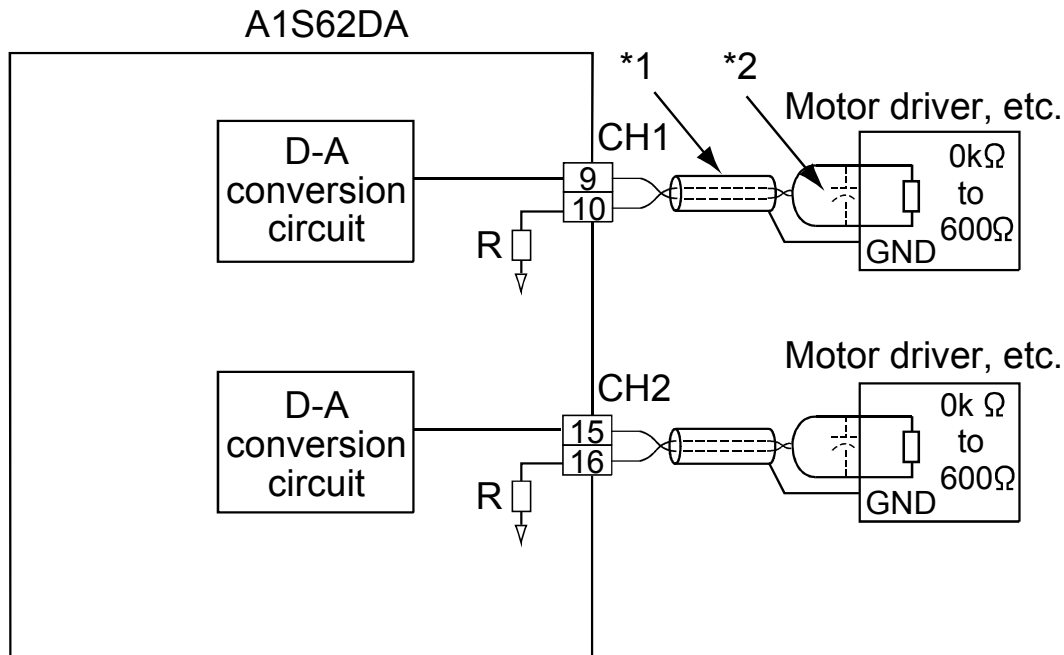

*1: Use two-core shielded wiring (twisted).

*2: If noise or ripple is generated by the external wiring, connect a 0.1 to 0.47μF (25V or more voltage resistance parts) to the input terminal of the external device.

Important

(1) The voltage and current output for the same channel cannot be used simultaneously.

Always open any terminals that are not being used as it is possible that if they are used they could cause damage to the internal elements.

(2) If current output is used, I-(COM) will become common and cannot be connected with equipment.

The output will normally cease.

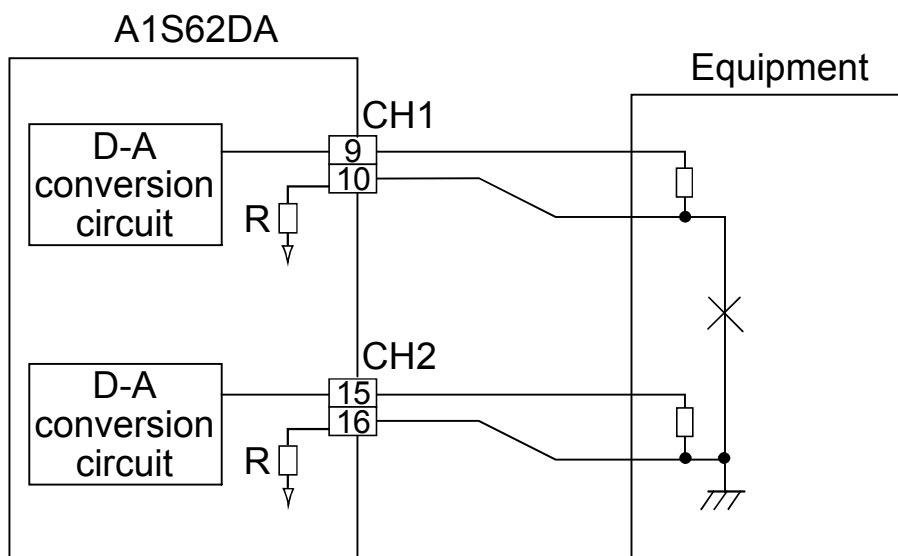

6. External Dimensions

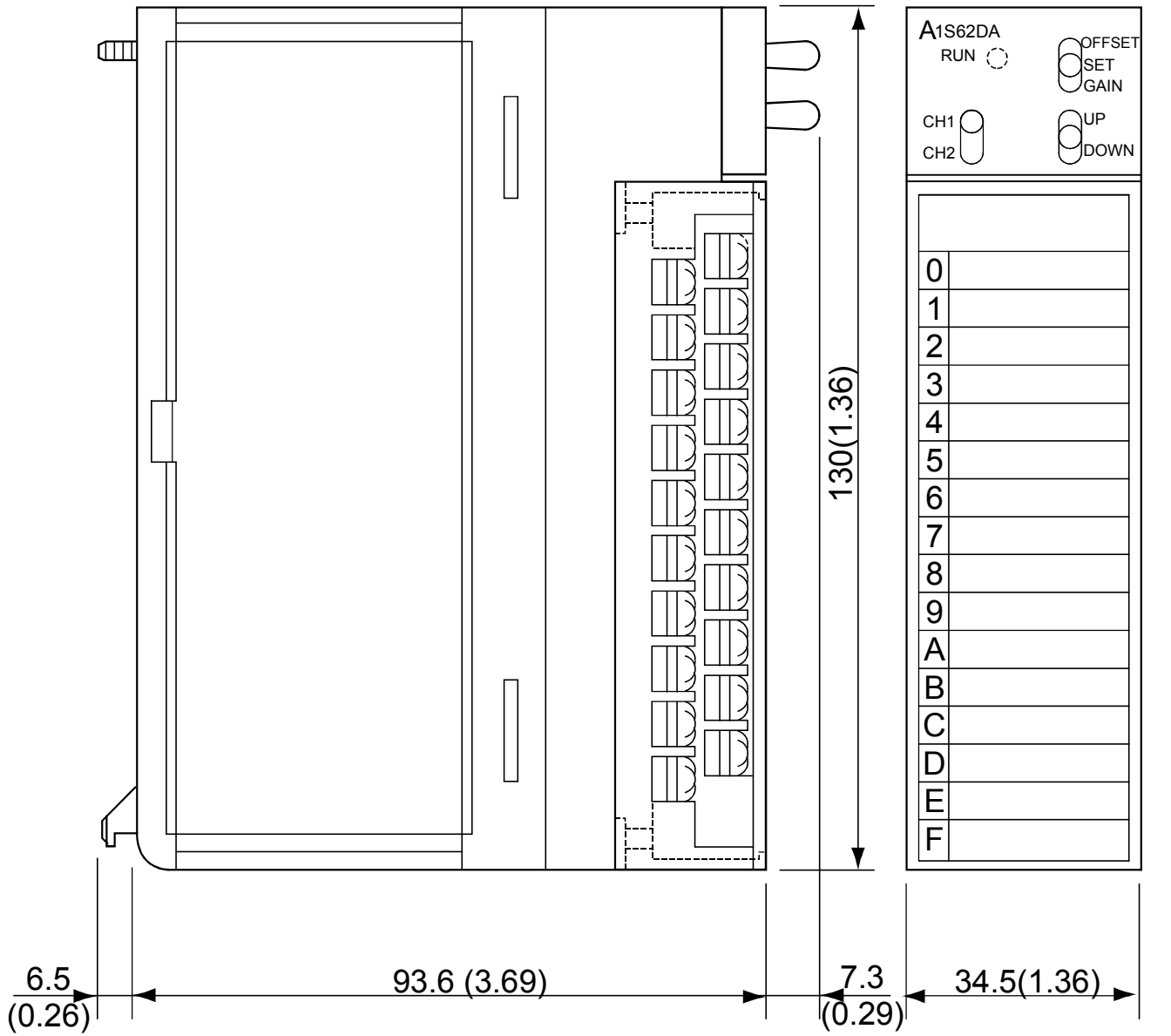

Unit:mm(inch)

WARRANTY

Mitsubishi will not be held liable for damage caused by factors found not to be the cause of Mitsubishi; machine damage or lost profits caused by faults in the Mitsubishi products; damage, secondary damage, accident compensation caused by special factors unpredictable by Mitsubishi; damages to products other than Mitsubishi products; and to other duties.

Country/Region Sales office/Tel		Country/Region Sales office/Tel	
U.S.A	Mitsubishi Electric Automation Inc. 500 Corporate Woods Parkway Vernon Hills, IL 60061, U.S.A. Tel : +1-847-478-2100	China	Mitsubishi Electric Automation (China) Ltd. 4/F Zhi Fu Plazz, No.80 Xin Chang Road, Shanghai 200003, China Tel : +86-21-6120-0808
Brazil	MELCO-TEC Rep. Com.e Assessoria Tecnica Ltda. Rua Correia Dias, 184, Edificio Paraiso Trade Center-8 andar Paraiso, Sao Paulo, SP Brazil Tel : +55-11-5908-8331	Taiwan	Setsuyo Enterprise Co., Ltd. 6F No.105 Wu-Kung 3rd.Rd, Wu-Ku Hsiang, Taipei Hsine, Taiwan Tel : +886-2-2299-2499
Germany	Mitsubishi Electric Europe B.V. German Branch Gothaer Strasse 8 D-40880 Ratingen, GERMANY Tel : +49-2102-486-0	Korea	Mitsubishi Electric Automation Korea Co., Ltd. 1480-6, Gayang-dong, Gangseo-ku Seoul 157-200, Korea Tel : +82-2-3660-9552
U.K	Mitsubishi Electric Europe B.V. UK Branch Travellers Lane, Hatfield, Hertfordshire., AL10 8XB, U.K. Tel : +44-1707-276100	Singapore	Mitsubishi Electric Asia Pte, Ltd. 307 Alexandra Road #05-01/02, Mitsubishi Electric Building, Singapore 159943 Tel : +65-6470-2480
Italy	Mitsubishi Electric Europe B.V. Italian Branch Centro Dir. Colleoni, Pal. Perseo-Ingr.2 Via Paracelso 12, I-20041 Agrate Brianza., Milano, Italy Tel : +39-039-60531	Thailand	Mitsubishi Electric Automation (Thailand) Co., Ltd. Bang-Chan Industrial Estate No.111 Moo 4, Serithai Rd, T.Kannayao, A.Kannayao, Bangkok 10230 Thailand Tel : +66-2-517-1326
Spain	Mitsubishi Electric Europe B.V. Spanish Branch Carretera de Rubi 76-80, E-08190 Sant Cugat del Valles, Barcelona, Spain Tel : +34-93-565-3131	Indonesia	P.T. Autoteknindo Sumber Makmur Muara Karang Selatan, Block A/Utara No.1 Kav. No.11 Kawasan Industri Pergudangan Jakarta - Utara 14440, P.O.Box 5045 Jakarta, 11050 Indonesia Tel : +62-21-6630833
France	Mitsubishi Electric Europe B.V. French Branch 25, Boulevard des Bouvets, F-92741 Nanterre Cedex, France Tel : +33-1-5568-5568	India	Messung Systems Pvt, Ltd. Electronic Sadan NO:III Unit No15, M.I.D.C Bhosari, Pune-411026, India Tel : +91-20-2712-3130
South Africa	Circuit Breaker Industries Ltd. Private Bag 2016, ZA-1600 Isando, South Africa Tel : +27-11-928-2000	Australia	Mitsubishi Electric Australia Pty. Ltd. 348 Victoria Road, Rydalmere, N.S.W 2116, Australia Tel : +61-2-9684-7777

MITSUBISHI ELECTRIC CORPORATION

HEAD OFFICE : TOKYO BUILDING, 2-7-3 MARUNOUCHI, CHIYODA-KU, TOKYO 100-8310, JAPAN
NAGOYA WORKS : 1-14, YADA-MINAMI 5-CHOME, HIGASHI-KU, NAGOYA, JAPAN

When exported from Japan, this manual does not require application to the Ministry of Economy, Trade and Industry for service transaction permission.

Specifications subject to change without notice.